

Tightening the Costs - Cutting the Screw

by Jozef Dominik

Reducing costs is the most common trend in economics of the industrially advanced countries. The assembly is a dominant operation in the technology of mechanical joining, which influences decisively not only the quality and reliability of the products but also continuous time of the production, the labor productivity and even the efficiency of the whole production system. It is very laborious and expensive operation with a high portion of the handicraft.

The Assembly Costs of the Bolted Joints and the Savings Possibilities

According to DIN 8593 "Manufacturing process joining" (paraphrased from C.O. Bauer: Handbuch der Verbindungstechnik) (Fig. 1) the screwing is the most widely used method of joining in the mechanical engineering and automotive industry.

There are several reasons why the screwing has a dominant position in the technology of

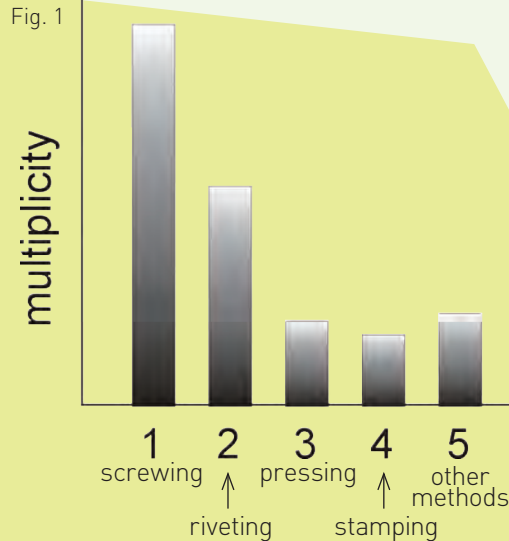

mechanical joining. The simple dismantlability of the joint is one of them; the second is that it can be repeatedly and exactly assembled. Despite the other bolted joints the screws have one notorious disadvantage - they have to overcome so-called idle threads while they start to tighten (Fig. 2)

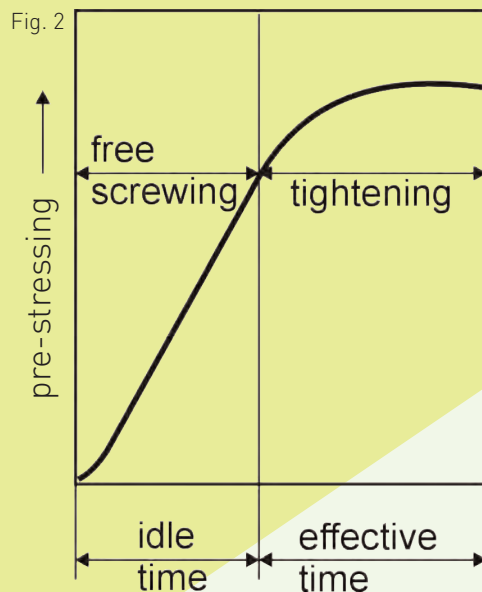

Figure 2 illustrates that almost 50 percent of the whole time for assembly is consumed for the overcoming the idle threads. Therefore it is logical that the development was focused on effective use of this phase and thus the self-tapping and self-drilling screws (Fig. 3) have arisen.

Their unique characteristic is that they "work" even during the idle time. The complete assembly is realized within one technological operation with one tool and in one

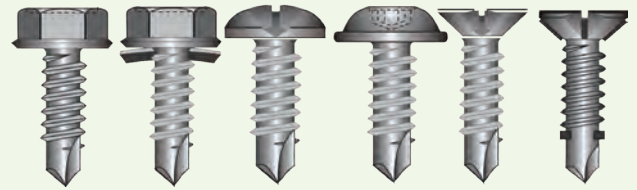

Fig. 3

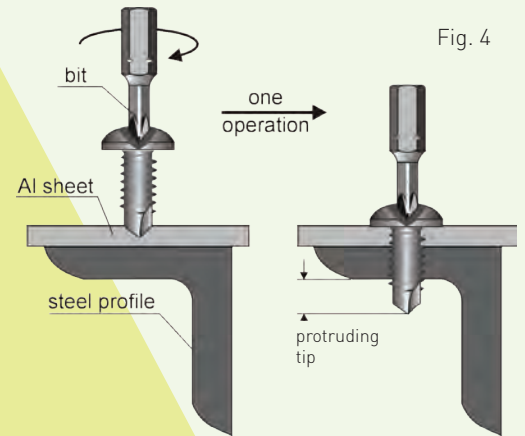

Fig. 4

assembly direction (Fig. 4). Here is a reminder of them.

The screws Flowdrill (Fig. 5), which create the assembly hole with the heat made by the point friction with the joined material, can be put into the same category. However, they have not found the wider employment in practice because the awkward heat material influence can occur in the surrounding of the assembly hole during the assembly.

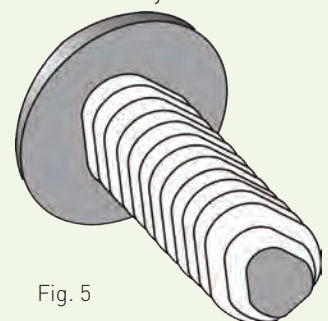

Fig. 5

The joint created with the screws mentioned in the last place in **Figure 3** is necessary to be considered as a highly sophisticated joint. These screws can bore a hole, cut a counter-thread and they even are embedded into the material. It is one of the typical multifunctional bolted joints.

The triangular self-thread forming screws (**Fig. 6**) are the specific category. They are defined by DIN 7500 and they are suitable mainly for aluminum profiles. The thread forming screws are used especially for automated fastening systems.

The triangular thread part cross-section of this screw enables to create a counter-thread made by forming which creates a highly firm joint resistant

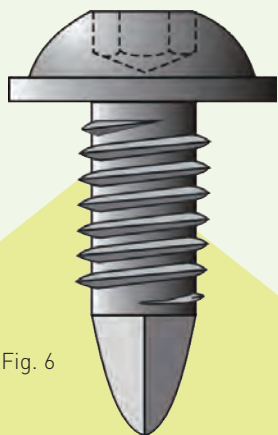

Fig. 6

to the loosening caused by vibrations.

The costs reduction of the assembly is generally enabled by the following remedies:

1. An assembly-oriented design.
2. Use of the standardized or unified construction elements.
3. As simple ways of fastening as possible.
4. Minimization of the assembly parts number and only one assembly direction.
5. The application of multifunctional bolted joints.
6. Minimization of the partition lines number.

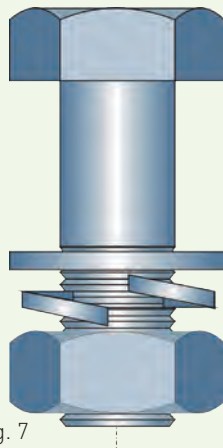

Fig. 7

The above-mentioned remedies are rather respected but in practice not realized. For instance, the combination of the washers in **Figure 7** should not be used at all because it is neither effective nor economically beneficial.

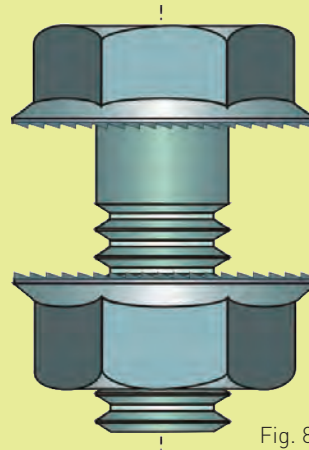

Fig. 8

A variant in **Figure 8** is technically and economically more beneficial. Flange joints reduce the number of the assembly joints and the partition lines, too. An example of the effective use of bolted joints multifunctionality is also represented by the system with a locking nut IstLock (**Fig. 9**) The main economical benefit is based on multiple repeatability.

Conclusion

The article pointed out some possibilities of the assembly costs reduction. These possibilities and many others represent a significant rationalization potential of bolted joints assembly.

Of course, there are a lot of other options which would deserve our attention. In any case a constructor has a key to "tightening the costs – cutting the screw" in his hands because he is responsible for the whole production economy and thus the products marketability. ■

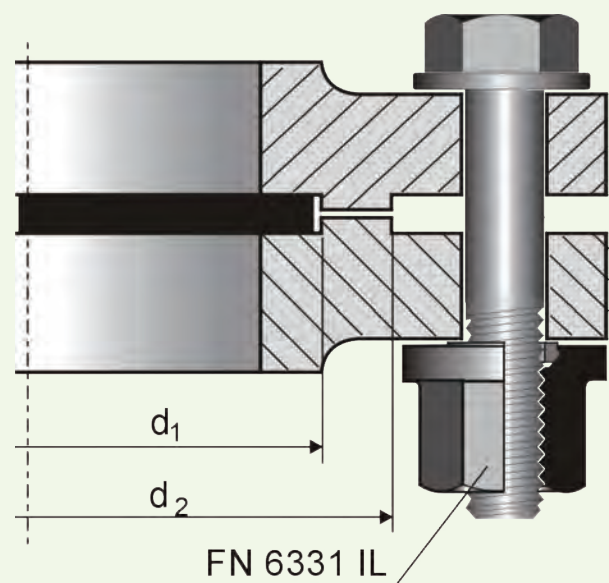

Fig. 9