



Round Table "E-commerce in the B2B Market of Fasteners"



Within the framework of the business program of the Moscow international exhibition MITEK 2019, an expanded round table "E-commerce in the B2B fastener market" will be held.

The purpose of the round table is to gather representatives of the leading Russian fastener companies and suppliers and to discuss the way that they managed to go in the field of electronic commerce. The format of the meeting includes interviews with the leading participants on a number of key issues and subsequent joint discussion with the audience. The participants with experience

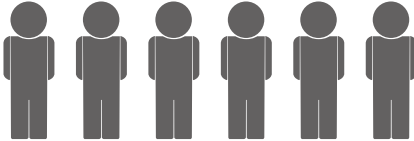

in e-commerce will be pre-selected. The organizer of the round table is the Editorial Board of the magazine "Fasteners, adhesives, tools and...".

The Moscow International Exhibition of Tools, Equipment and Technologies MITEK, the central instrumental event in Russia, will be held in November, 2019 from November 5 to 8 at the EXPOCENTRE Fairgrounds in Pavilions No. 2 and No. 8.

Fastener Businessmen Day in St. Petersburg



An important part of conferences, business seminar is informal communication, as a result of which new information, new contacts help business development. The participants of the Petersburg club of fastener suppliers decided to hold an extended meeting for fastener businessmen without unnecessary formalities.

Such a meeting took place on June 19 in the center of St. Petersburg in a cozy

Czech brewery. It was organized by Vyacheslav Tarasov (CKI group of companies) and Alexander Ostashov. They marked this event as "Fastener Businessmen Day". The leaders of 35 St. Petersburg companies, involved in the production and sale of fasteners, met for free communication and tasting branded beer. If the vacation time had not begun, there would have been more participants - this was shown by the responses to the invitations (about a hundred invitations were sent before the meeting).

The meeting was filled with communication. It was indicative and "evidence" that in the hall, where the beer was brewed, people, passionate about their fastener business, gathered together. A blitz survey, conducted by the meeting organizers, fully confirmed this. All participants said that they were interested in such format of meetings. Some of the participants formulated their wishes on a list of the topics, actual for fastener businessmen, for future meetings and voiced their readiness to provide a meeting room.

Severstal-metiz Produced the Record Amount of Screws

The company produced 872 tons of various types of screws. The previous record of 788 tons had been set in October 2018. Railway screws are widely used for the construction and repairing of all types of railways and the underground.

"We achieved this record thanks to coordinated work of operators, mechanics and electricians. They constantly monitored the efficiency of the equipment, timely eliminated the causes of breakdowns and carried out work to prevent downtime. The teams for project development of the product area contributed to the record. They proposed measures that increased the productivity," commented Sergey Kovryakov, CEO of Severstal-metiz.

Also, this year the company celebrates its 15th anniversary. Severstal-metiz was established on July 1, 2004 as a management company for three plants: Cherepovets Steel Rolling Plant OJSC (Cherepovets), Orel Steel Rolling Plant OJSC (Orel), and VolgoMetiz LLC (Volgograd).



"Now Severstal-metiz is among the largest hardware companies in Russia. Our share in the domestic market is about 21%. And the product portfolio has over 100 thousand items. All these successes are due to a large team of Severstal-metiz employees, our partners and customers," says Sergey Kovryakov, Severstal-metiz CEO.



Metinvest Joins Dutch Association of the Metallurgical Industry (VNMI)



Metinvest B.V. (the Netherlands), the parent company of Metinvest Group, the international vertically integrated group of steel and mining companies, has joined the Dutch Association of the Metallurgical Industry (VNMI).

The Dutch trade association of producers of raw materials, semi-finished products and finished metallurgical products was established in 2000. VNMI unites more than 80% of the players in the metallurgical industry of the Netherlands. The association represents Dutch steelmakers in European business associations in The Hague and Brussels. VNMI focuses on four areas: health and safety; energy and climate; sustainability and CSR; and trade and innovation.

Metinvest Group has been developing in these areas since its inception. The Group supports global initiatives and participates in international environmental projects. In 2010, Metinvest joined the UN Global Compact.

Metinvest is also the first and only Ukrainian member of the World Steel Association (worldsteel), whose members represent around 85% of global steel production.

Yuriy Ryzhenkov, CEO of Metinvest Group: “For Metinvest, Europe is a key market. We have four re-rolling plants there. We sell more than a third of our products in European countries. Joining VNMI is evidence that the Group operates in accordance with the best European business practices. Membership in the association will allow us to share our experience with other market players, as well as to participate in the development of new rules and requirements for metallurgy in EU countries.”

Belarus Steel Work Has a New CEO

The new CEO of BSW is Dmitry Korchik. His appointment to this position was agreed with the President of the Republic of Belarus.

Dmitry Korchik has rich experience in the structure of the Ministry of Industry. He began his career as an apprentice turner. From 2002 to 2012 he worked in the central office of the Ministry of Industry, where at different times he had to deal with energy resources, foreign economic activity, and investment. Since 2012, Dmitry Korchik was a director for industrial and technical policy and development of OJSC “Borisov plant of automotive and tractor electrical equipment”. Since March 2015, he was a Deputy Minister of Industry of the Republic of Belarus.

“Dear colleagues,” said Dmitry Korchik, “In any work, the most valuable thing for me is people. BSW has a professional and well-coordinated team. I believe that through dialogue we will make decisions that will allow the company to go forward and develop.”



LCS 40 Years Experience in Stamping Manufacturing in Taiwan

Production Specification:

Thickness: Max. 6.5mm
 Material: Low/Mid/High Carbon, Stainless, Brass, Copper, Aluminum
 Finish: Galvanized, Nickel, GEOMET, DACROMET, Powder Coating, Phosphate, Hot Dip Galvanized, Black Oxide, Sand Blasting...

Strict Quality Control:

- ▶ Inspection on each process
- ▶ Regular inspection during forming process (IPQC)
- ▶ Traceability of material no., each process, equipment used, and personnel involved in

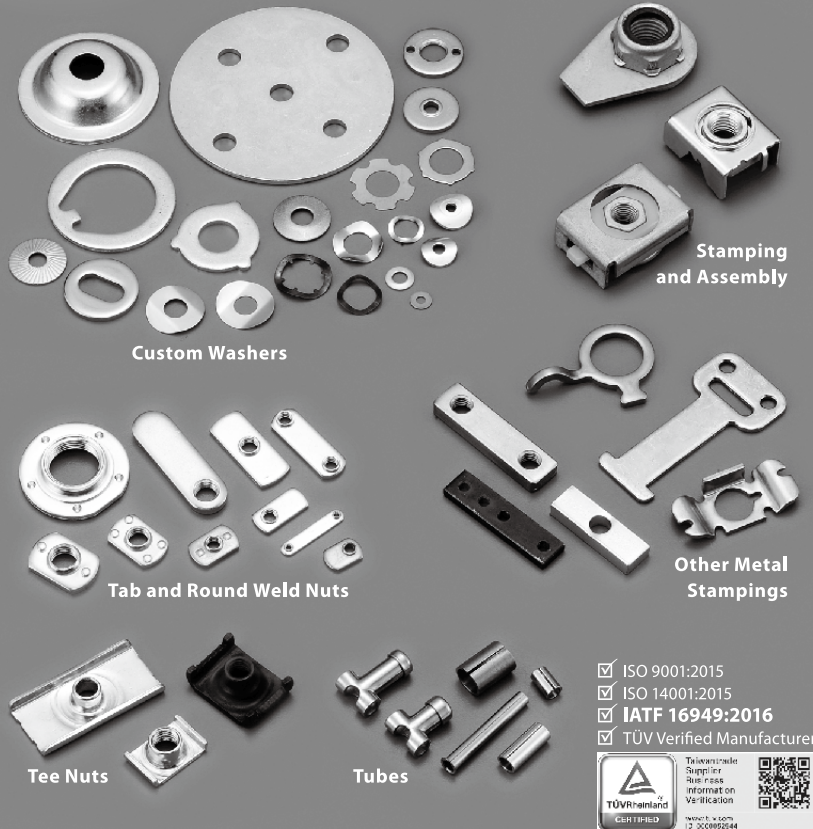

- ☑ ISO 9001:2015
- ☑ ISO 14001:2015
- ☑ IATF 16949:2016
- ☑ TÜV Verified Manufacturer



LIAN CHUAN SHING INTERNATIONAL CO., LTD.

No. 276, Chihkan N. Rd., Zinguan Dist., Kaohsiung City 826, Taiwan
 Tel: +886-7-610 6213 Fax: +886-7-619 2270 / 619 5685
 Email: sales@lian-chuan-shing.com.tw http://www.lian-chuan-shing.com.tw
 http://www.fastener-world.com.tw/en/supplier/lcs

